

Bienvenidos Polímeros Propiedades



Estructura

Caracterización

Propiedades

Aplicaciones

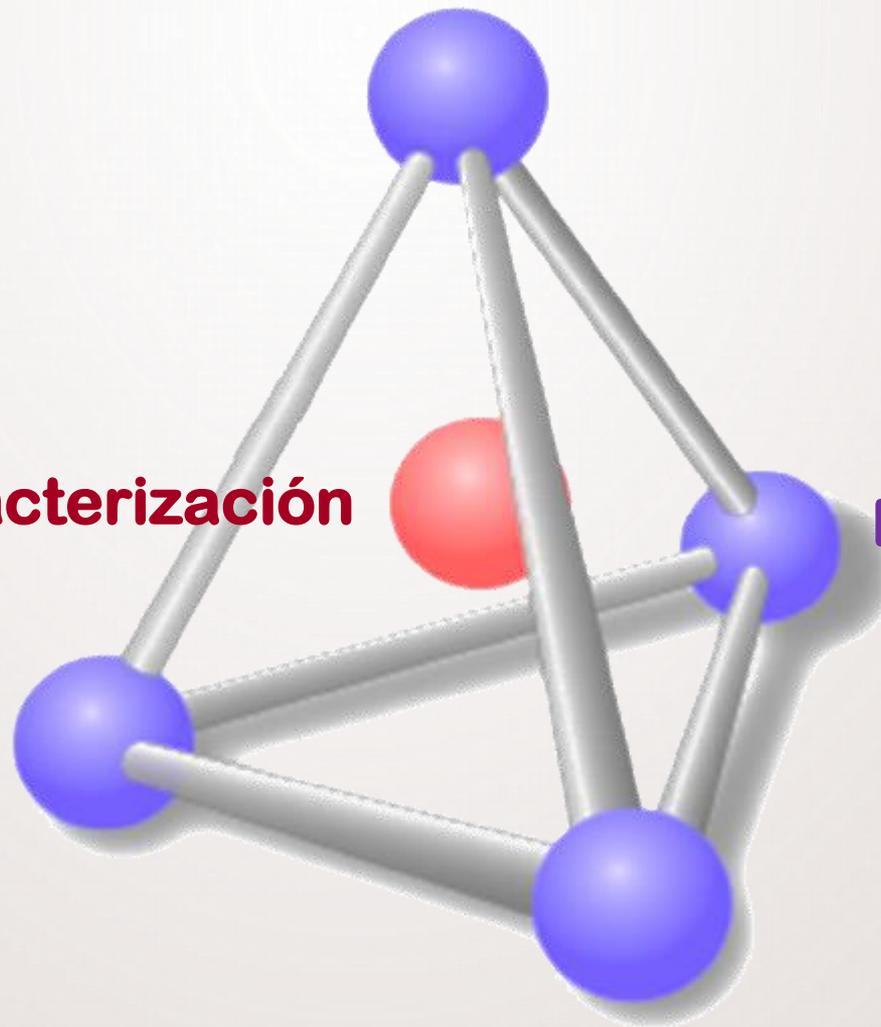

Procesamiento

Tipos de enlaces químicos

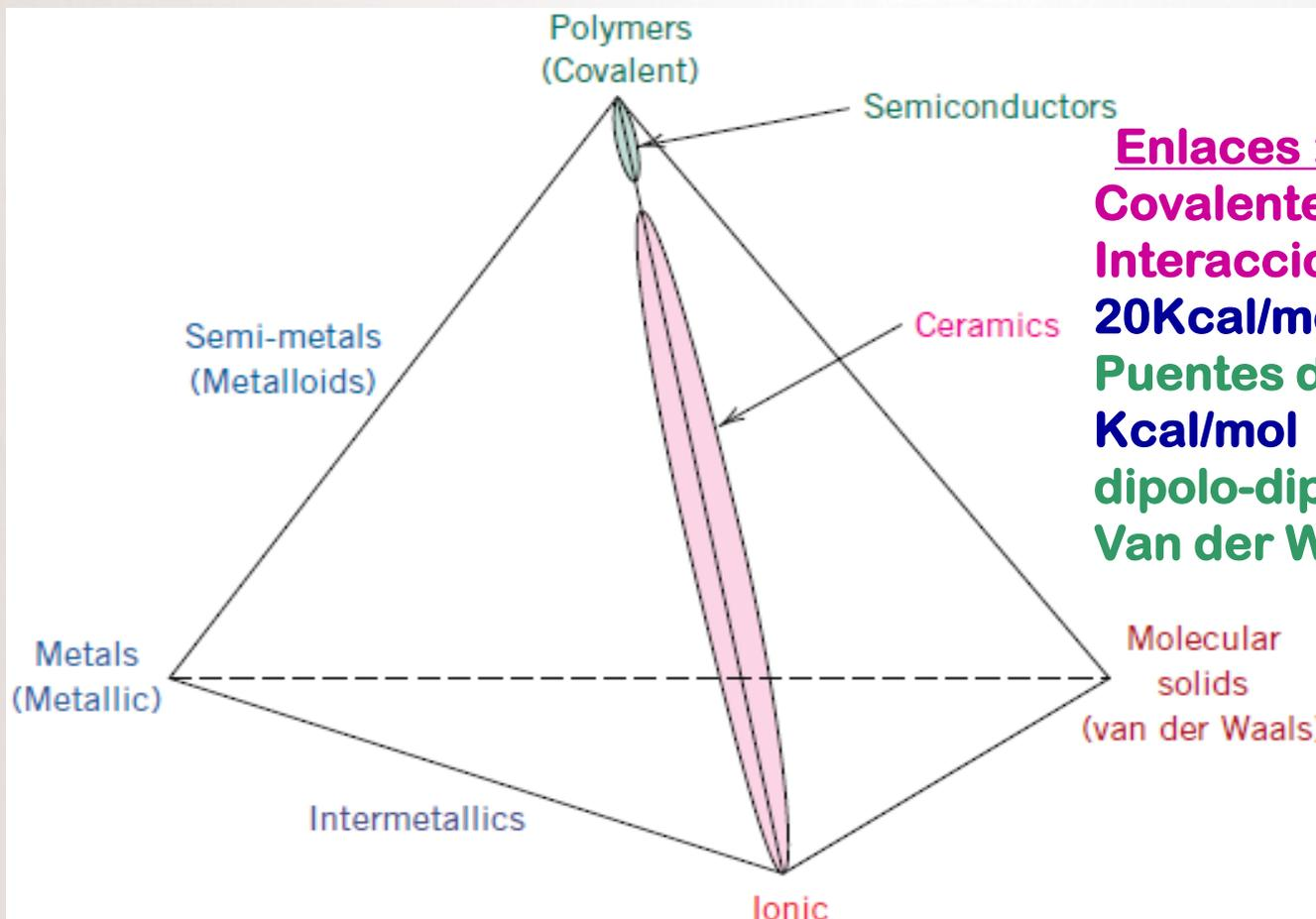

Enlaces : energía de disociación

Covalente: 200-500 Kcal/mol

Interacciones iónicas : 10-20Kcal/mol

Puentes de hidrógeno : 3-7 Kcal/mol

dipolo-dipolo : 1,5-3 Kcal/mol

Van der Waals : 0,5-2 Kcal/mol



Definiciones

- MATERIAL FORMADO POR MOLÉCULAS QUE TIENEN LARGAS SECUENCIAS DE UNO O MÁS TIPOS ÁTOMOS (UNIDADES REPETITIVAS: MONÓMERO O MATERIAL DE PARTIDA) UNIDAS ENTRE SI POR ENLACES COVALENTES.
- ESTAS MOLÉCULAS (MACROMOLÉCULAS) PUEDEN TENER ESTRUCTURA: **LINEAL, RAMIFICADA O ENTRECruzADA.**



Clasificación

comportamiento Térmico

- Termoplásticos (PE, PP, PS, PVC)
- Termorrígidos (resinas fenólicas y epoxi)

Química de la síntesis

- Polimerización en etapas (Poliéster, poliamida, poliuretano)
- Polimerización en cadena (PE, PVC)

La estructura

- Lineal (homopolímeros) y copolímeros: al azar o en bloque)
- Ramificado (copolímero injerto)
- Entrecruzada (epoxi-amida)

La materia prima y la degradabilidad

- Materiales primas renovables (No biodegradables, Biodegradables)
- Materiales primas no renovables (No biodegradables, Biodegradables)



POR SU COMPORTAMIENTO TÉRMICO

Termoplásticos
Hielo-soldadura

Semi-cristalinos
amorfos

- Pueden fundirse y ser moldeados
- solubles
- lineales o ramificados
- PS, PMMA, PE

Termoestables
Huevo-concreto

amorfos

- Se “curan” en el molde y se reforman sólo por maquinado
- insolubles
- entrecruzados
- resinas epoxi, fenólicas, poliuretanos



POR LA SÍNTESIS QUÍMICA

Cinética de reacciones de polimerización





POR LA SÍNTESIS QUÍMICA

Polimerización por adición

Cada átomo de la molécula del monómero pasa a formar parte del polímero

Polimerización por condensación

Parte de la molécula de monómero se pierde cuando el monómero pasa a formar parte del polímero



LA ESTRUCTURA

Cadena lineal



Cadena ramificada



Redes poliméricas





LA MATERIA PRIMA Y LA BIODEGRADABILIDAD



Materia prima renovable

No
biodegradables
BioPE, BioPP,
BioPET, BioPA

Bioplásticos^(a)
PLA, PHA, TPS

No Biodegradables

Biodegradables

No
biodegradables
PE, PS, PP, PET

Biodegradables^(d)
PCL, PBS, PBHT

Materia prima no renovable



BIOPOLÍMEROS



Bioplásticos

Fósil

Biodegradables

Compostables

Bio-basados

1°G

Plantas ricas en carbohidratos como el maíz o la caña de azúcar, llamados cultivos alimentarios

2°G

cultivos no alimentarios o subproductos de la 1° G. Madera, celulosa

3°G

Biomásas a partir de algas, residuos agroindustriales y municipales, biotecnología y nanotecnología



Disposición final de los materiales plásticos

Reciclado

Reúso

Mecánico

Químico

Orgánico

**Rellenos
sanitarios**

**Recuperación
energética**



Reciclaje Biológico

Biodegradación

Principalmente
 H_2O , CO_2 , biomasa

Tierra

**Vertedero
Anaerobio**

**Compostaje
aerobio**

Agua

Dulce

Salobre

Océano



Biodegradable

- Tierra
- Agua

Compostable

Abono



Oxobiodegradable

Aditivos que
fragmentan
Microplásticos

Oxo-degradable



Economía circular



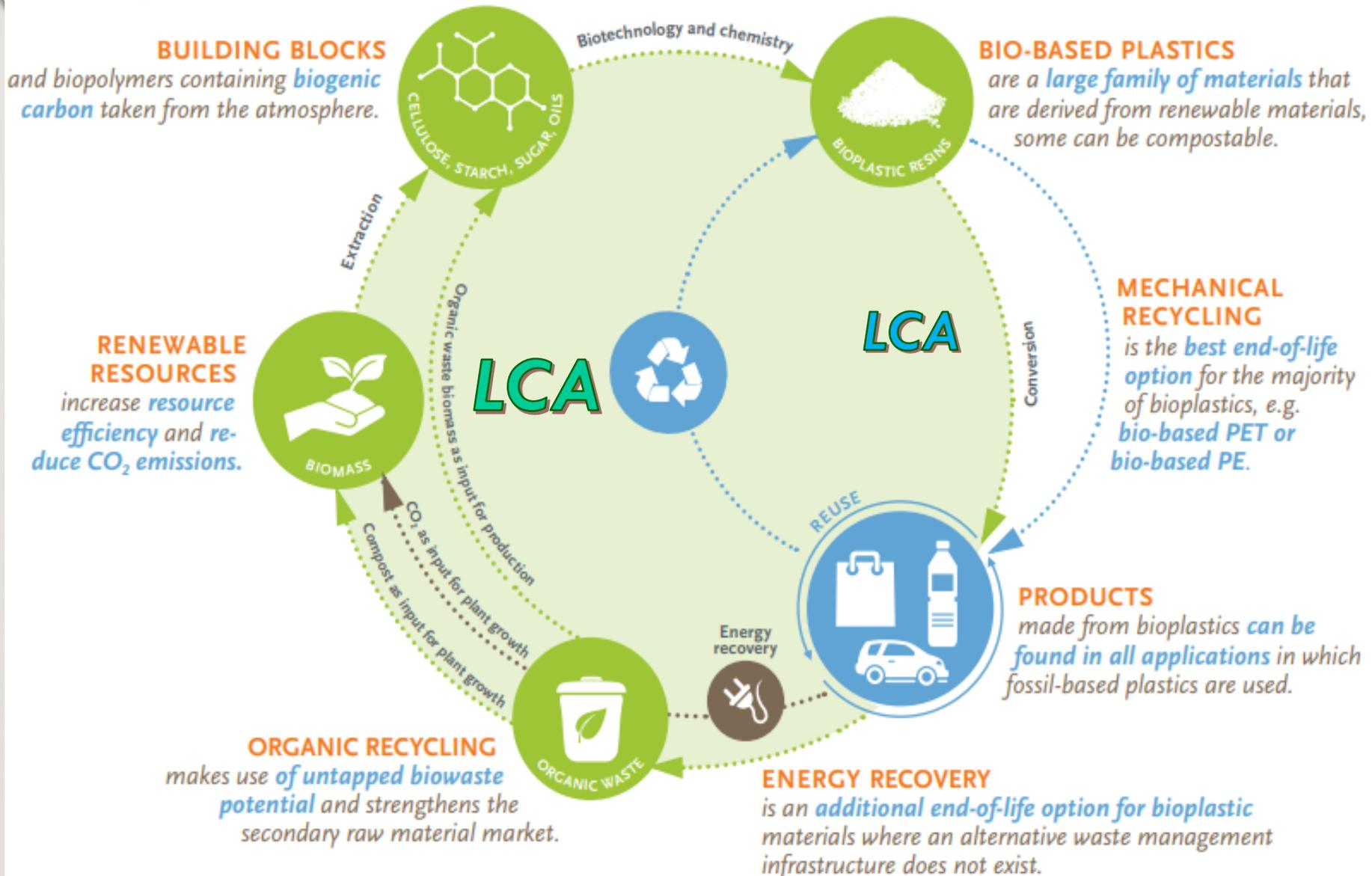



SÍMBOLOS O SELLO COMPOSTABILIDAD

 <p>American standard ASTM 6400</p>	 <p>European standard EN 13432 Australian standard AS 4736</p>	 <p>European standard EN 13432</p>	 <p>Home composting</p>
	 <p>Japanese standard GreenPla</p>	 <p>Canadian standard CAN/BNQ 0017-088</p>	 <p>Italian certification CIC</p>



Reciclaje Mecánico/Químico



PET
POLIETILEN-
TEREFTALATO



HDPE
POLIETILENO
DE ALTA
DENSIDAD



PVC
POLICLORURO
DE
VINILO



LDPE
POLIETILENO
DE BAJA
DENSIDAD



PP
POLIPROPILENO



PS
POLIESTIRENO



OTHER
OTROS

SEPARACIÓN



MOLIENDA
Y LAVADO



SECADO



RECICLADO MECÁNICO

EXTRUSIÓN



GRANULACIÓN



PELLETS
RECICLADOS

AGLUTINACIÓN



PELLETS
RECICLADOS



Plásticos



Aplicaciones

Gomas y elastómeros



Fibras



Acabado superficial Recubrimientos protectores



Adhesivos



Espumas





PRUEBAS de los POLÍMEROS

PROPIEDADES FÍSICAS

- Propiedades mecánicas.
- Propiedades térmicas.
- Propiedades ópticas
- Propiedades eléctricas.

PROPIEDADES QUÍMICAS

Son aquellas que involucran reacciones químicas y por tanto cambios en los enlaces primarios de los materiales.

- **Temperatura de ignición e inflamabilidad.** Poder calorífico o calor de combustión
- **solubilidad o resistencia a los disolventes.** pH.
- **Propiedades ambientales**
(corrosividad, toxicidad, estabilidad)



Propiedades Físicas

Ensayos mecánicos

Propiedades Físicas

Los **mecanismos de deformación** de los materiales poliméricos se clasifican en tres grandes grupos:

1. Estiramiento de enlaces



DEF. ELÁSTICA

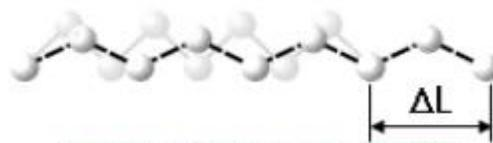

2. Alineación cadenas



DEF. ELÁSTICA/PLÁSTICA

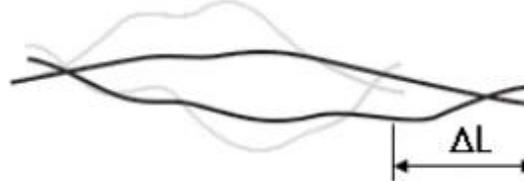

3. Deslizamiento cadenas



Comportamiento del polímero como resorte. Ley Hooke, recuperable.

Cadenas forma ovillo. Depende de la estructura: recuperable o permanente

Deslicen unas cadenas con respecto a otras al aplicar una fuerza de cizalla o corte. NO RECUPERABLE, incide def. plástica.



Comportamiento viscoelástico

comportamiento mecánico depende de la variable tiempo debido a la naturaleza viscoelástica de los materiales poliméricos.

**Comportamiento a corto
plazo**
Independiente del tiempo
preselección
Control de calidad

Comportamiento a largo plazo
Depende del tiempo
**Se produce el fenómeno que
condiciona la utilización de los
polímeros.**

- **Comportamiento elástico**
- **Comportamiento viscoso**

Fluencia –relajación- isócrono
Diseño y cálculo

Comportamiento viscoelástico

FLUENCIA

$$\sigma = Cte ; \varepsilon = f(t)$$

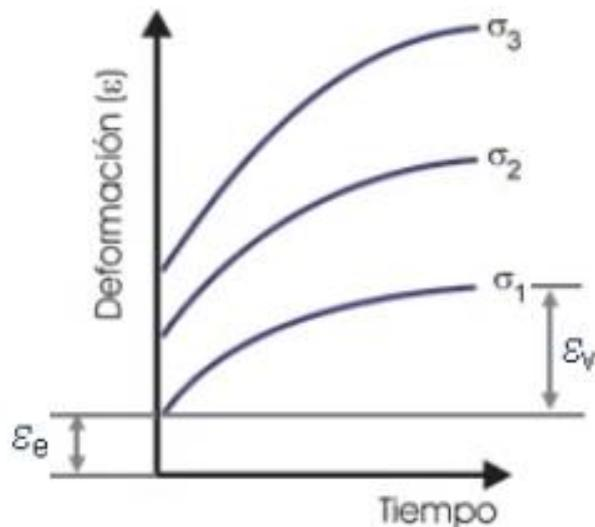

RELAJACIÓN

$$\varepsilon = Cte ; \sigma = f(t)$$

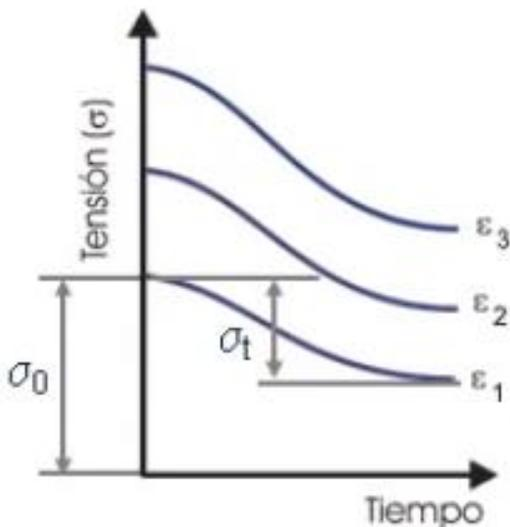

COMP. ISOCRONO

$$t = Cte ; \varepsilon = f(\sigma)$$

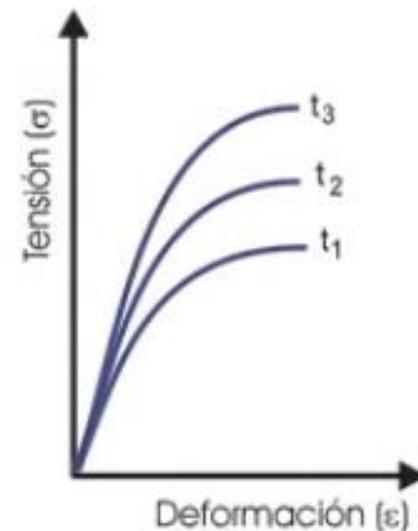

Conceptos esfuerzo y deformación

Tracción

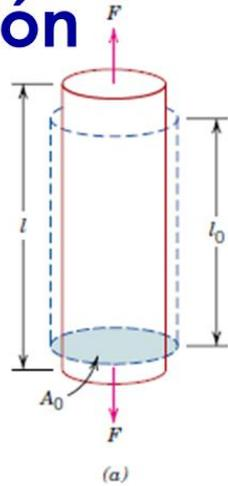

Compresión

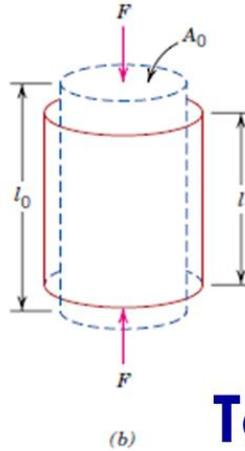

Torsión

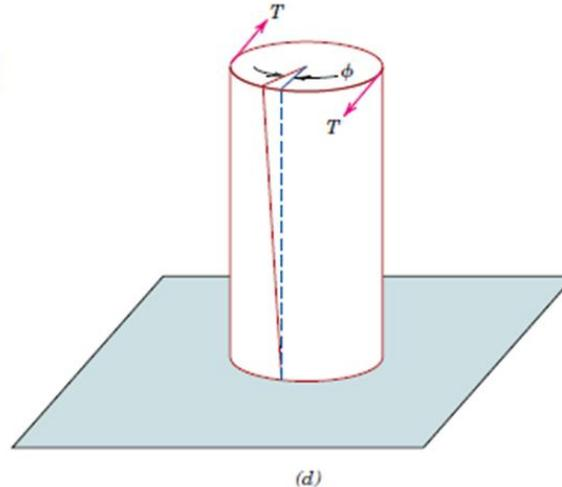

Cizalladura

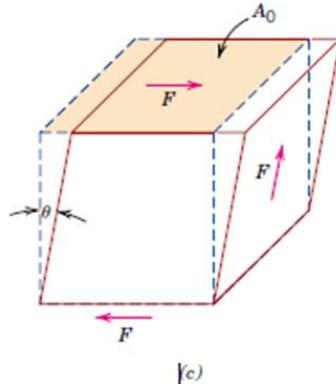

Ensayo de tracción

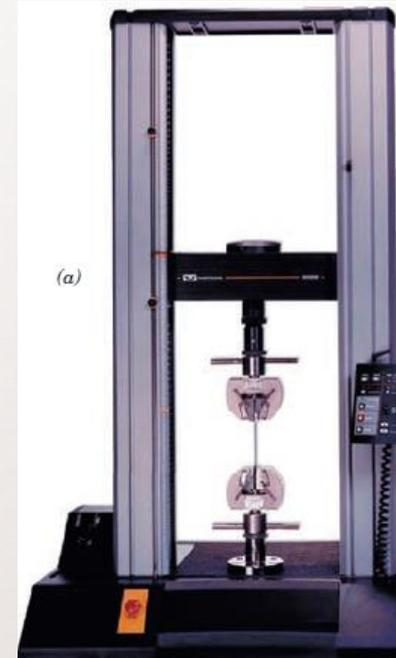
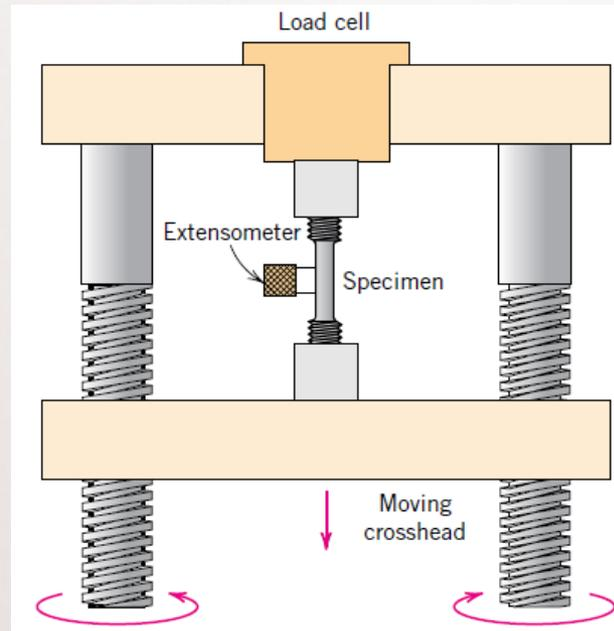
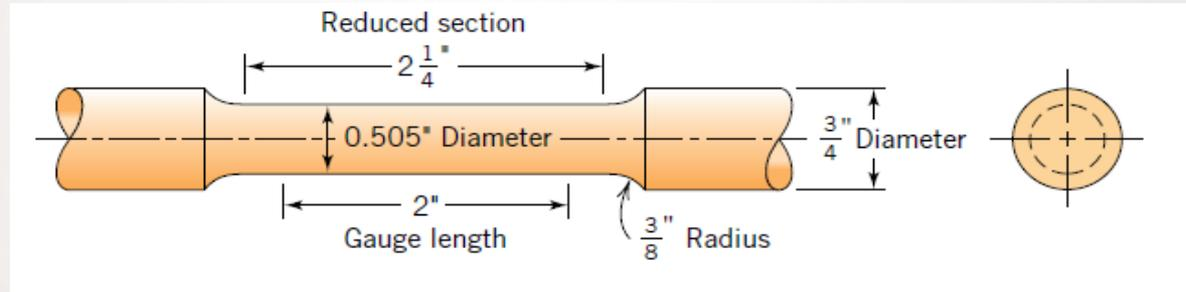

Ensayo de tracción

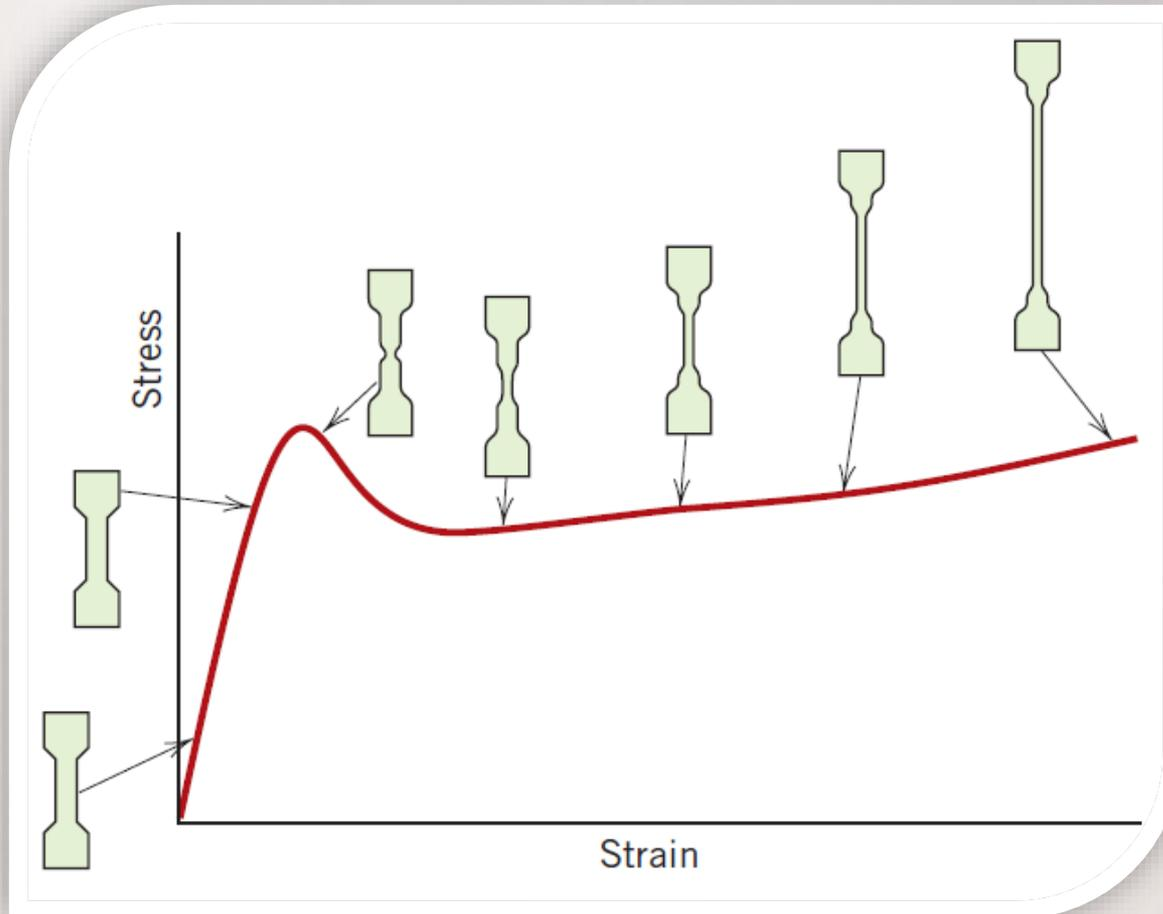

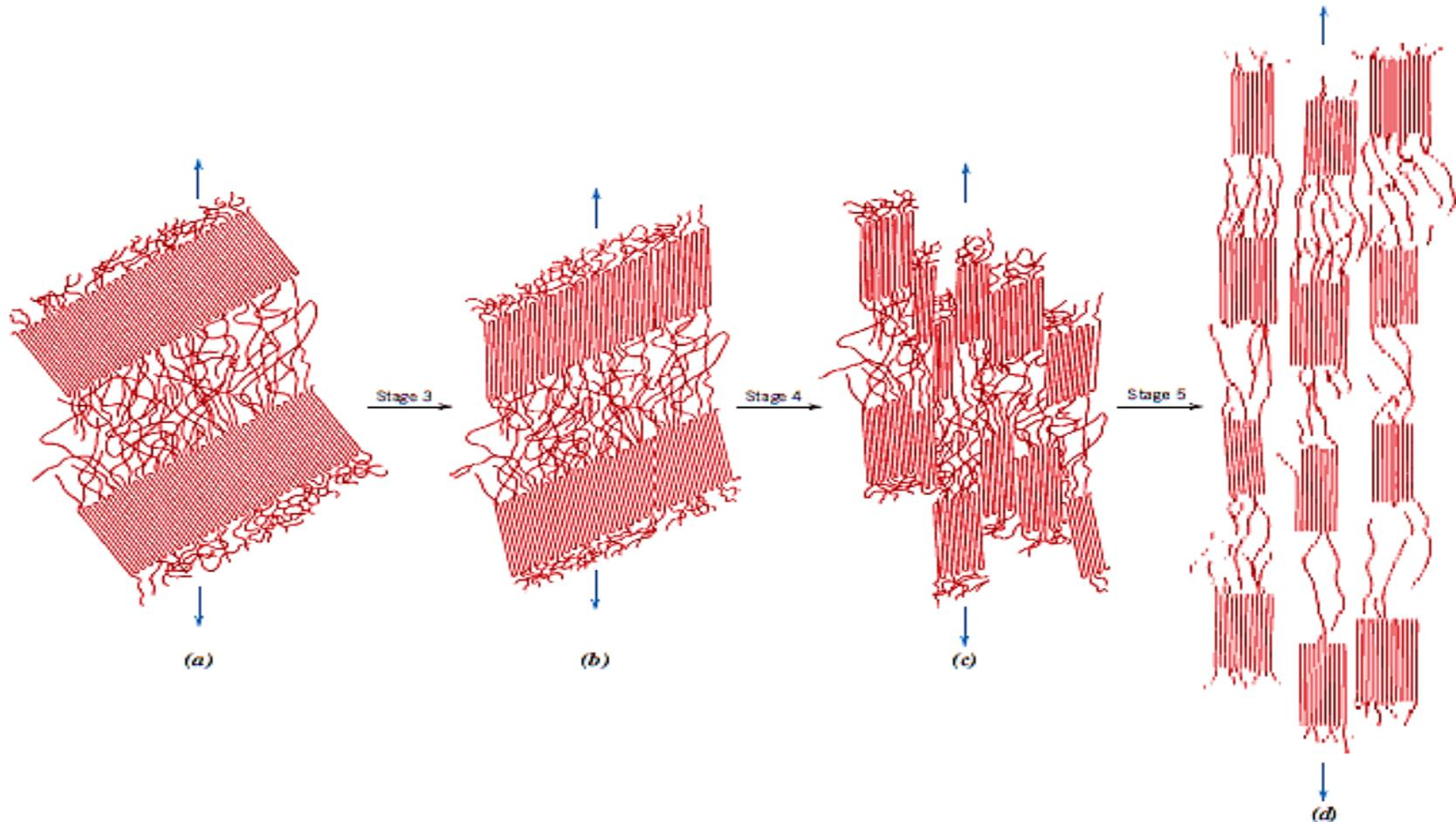
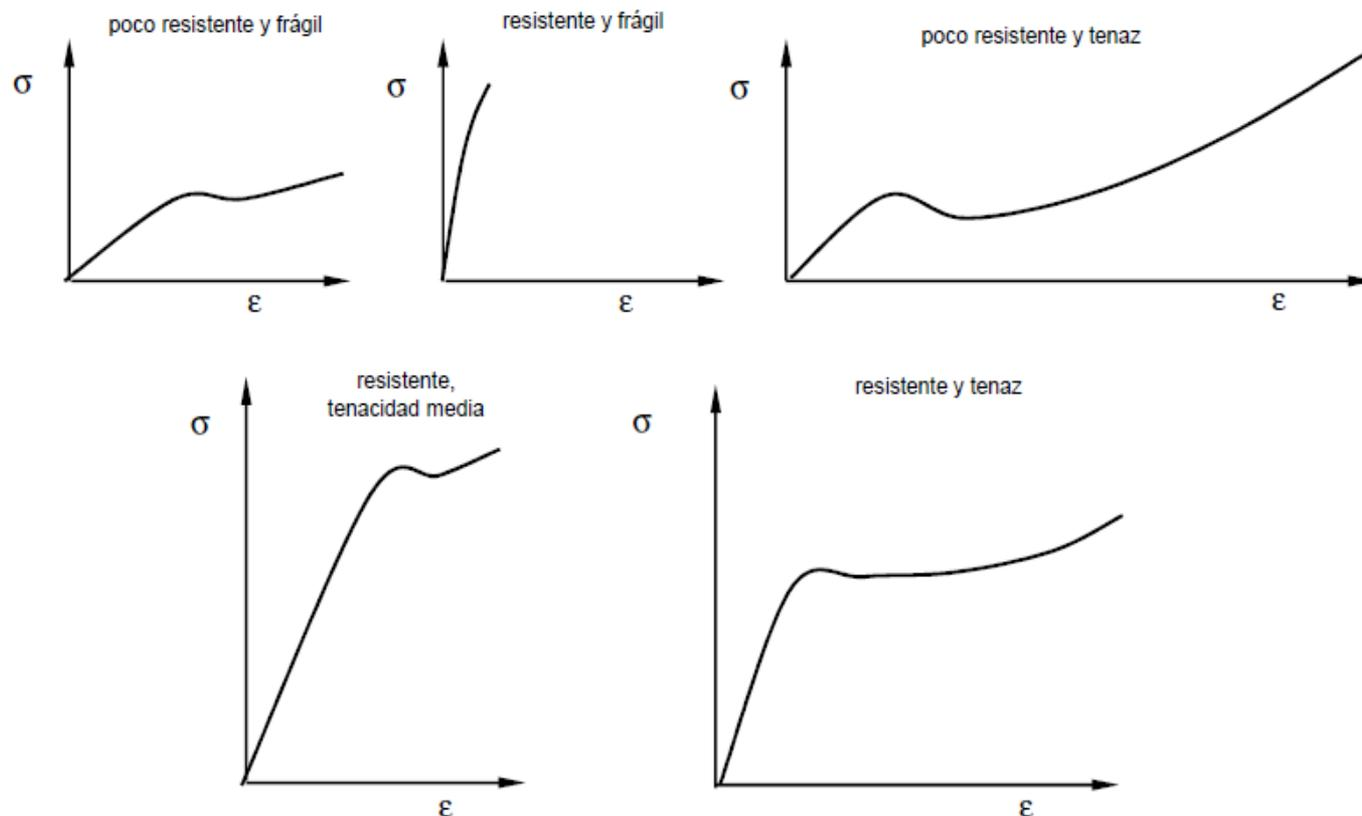

Figure 15.13 Stages in the plastic deformation of a semicrystalline polymer. (a) Two adjacent chain-folded lamellae and interlamellar amorphous material after elastic deformation (also shown as Figure 15.12c). (b) Tilting of lamellar chain folds. (c) Separation of crystalline block segments. (d) Orientation of block segments and tie chains with the tensile axis in the final plastic deformation stage.
(From SCHULTZ, POLYMER MATERIALS SCIENCE, 1st Edition, © 1974. Reprinted by permission of Pearson Education, Inc., Upper Saddle River, NJ.)



Propiedades del ensayo de tracción



Clasificación de los polímeros en términos de su comportamiento mecánico

Propiedades del ensayo de tracción

Típicas curvas esfuerzo-deformación

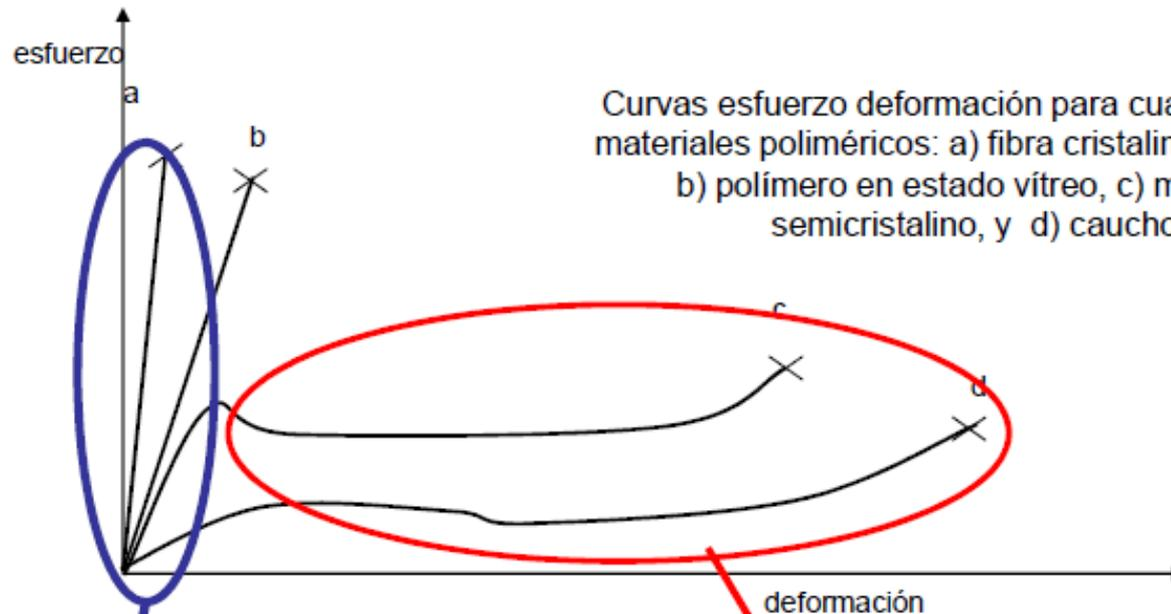

Curvas esfuerzo deformación para cuatro tipos de materiales poliméricos: a) fibra cristalina orientada, b) polímero en estado vítreo, c) material semicristalino, y d) caucho

Comportamiento a bajas deformaciones: Rango elástico (metales, cerámicas (deformaciones <math><0.5\%</math>) y viscoelástico (polímeros) (deformaciones menores 1%)

Comportamiento a elevadas deformaciones: Comportamiento plástico



Propiedades del ensayo de tracción

Influencia de las condiciones de experimentación

Efecto de la temperatura

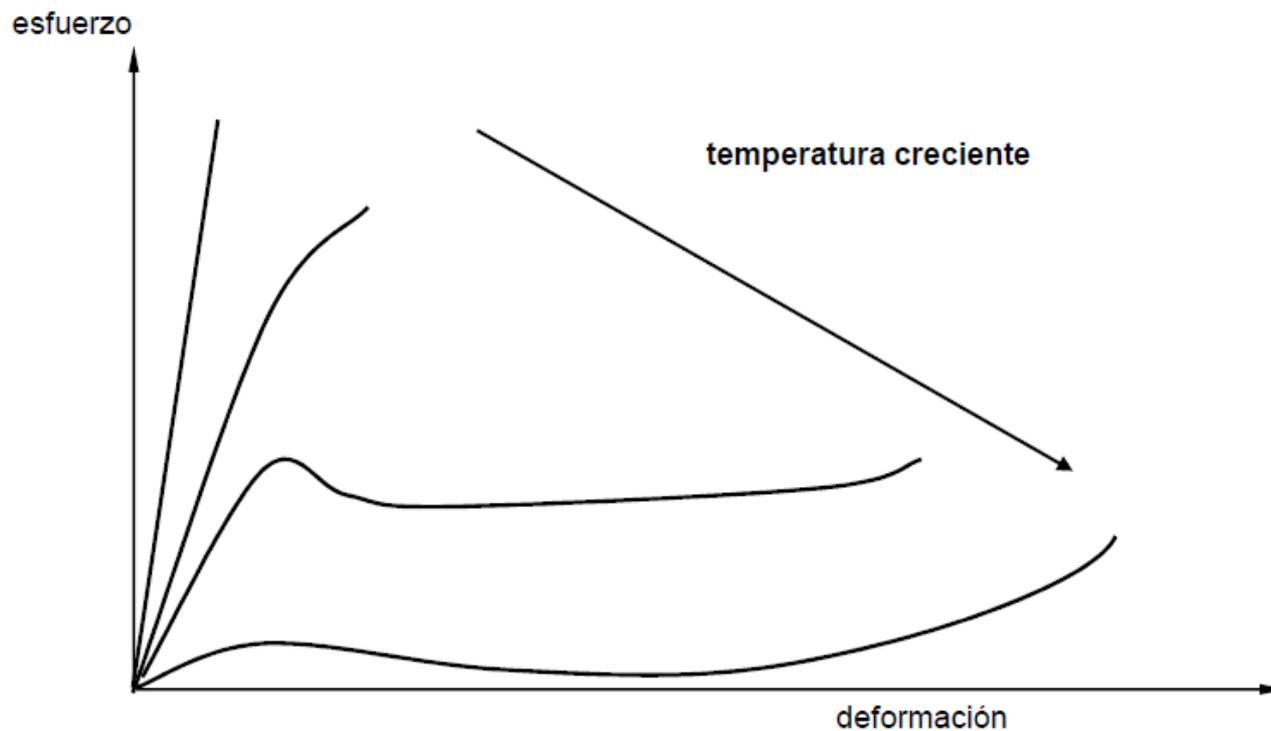



Propiedades del ensayo de tracción

Efecto de la velocidad de deformación

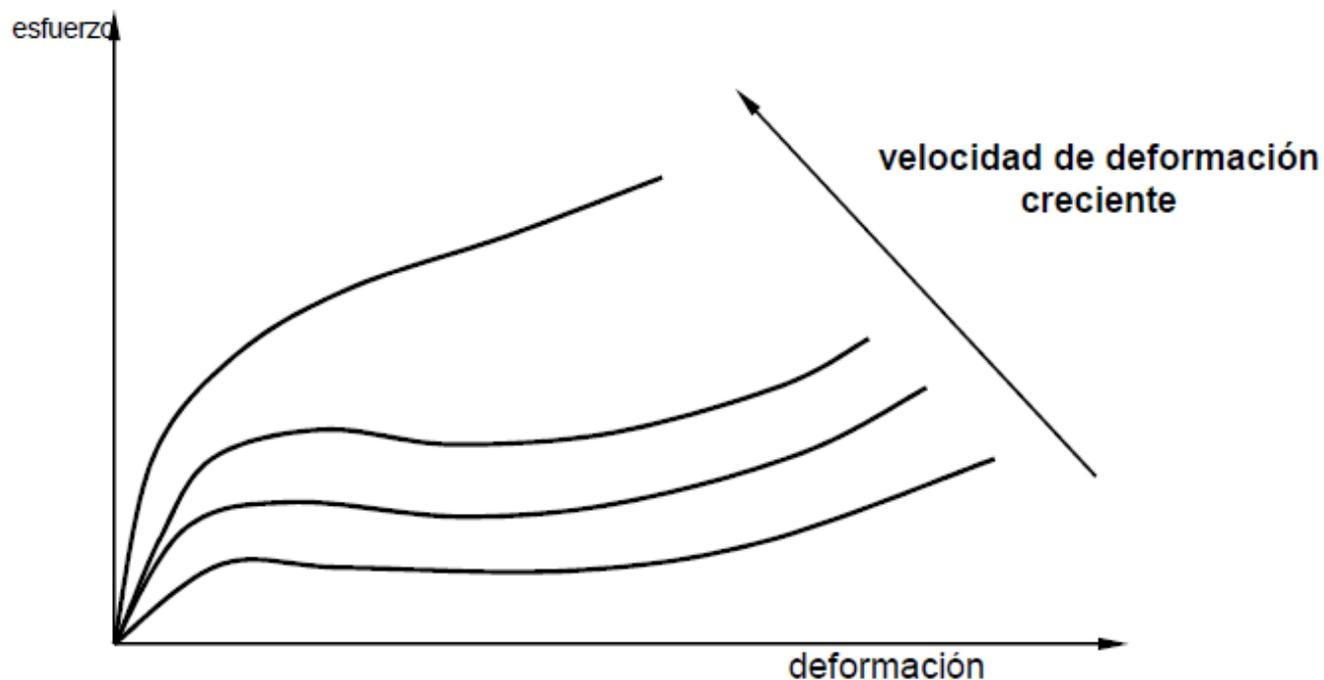

Efecto de la velocidad de deformación en el comportamiento a tracción de un polímero



Propiedades del ensayo de tracción

COMPORTAMIENTO MECÁNICO A CORTO PLAZO

Materia	Siglas	Densidad (Kg m ⁻³)	Tensión de rotura (MN m ⁻²)	Módulo a flexión (GN m ⁻²)	Alargamiento a la rotura (%)
Poliétileno baja densidad	LDPE	0,92	10	0,2	400
Poliétileno alta densidad	HDPE	0,95	32	1,2	150
Polipropileno	PP	0,905	33	1,5	150
Poliestireno	PS	1,05	40	3,0	1,5
Poliámidá 66	PA66	1,14	70	2,8	60
Policarbonato	PC	1,15	65	2,8	100
Poliétiléntereftalato	PET	1,36	75	3	70
Estireno acrilonitrilo	SAN	1,08	72	3,6	2
Poliéter éter cetona	PEEK	1,30	62	3,8	4
Poliéterimida	PEI	1,27	105	3,3	60
Poliétersulfona	PES	1,37	84	2,6	60



Ensayo de tracción

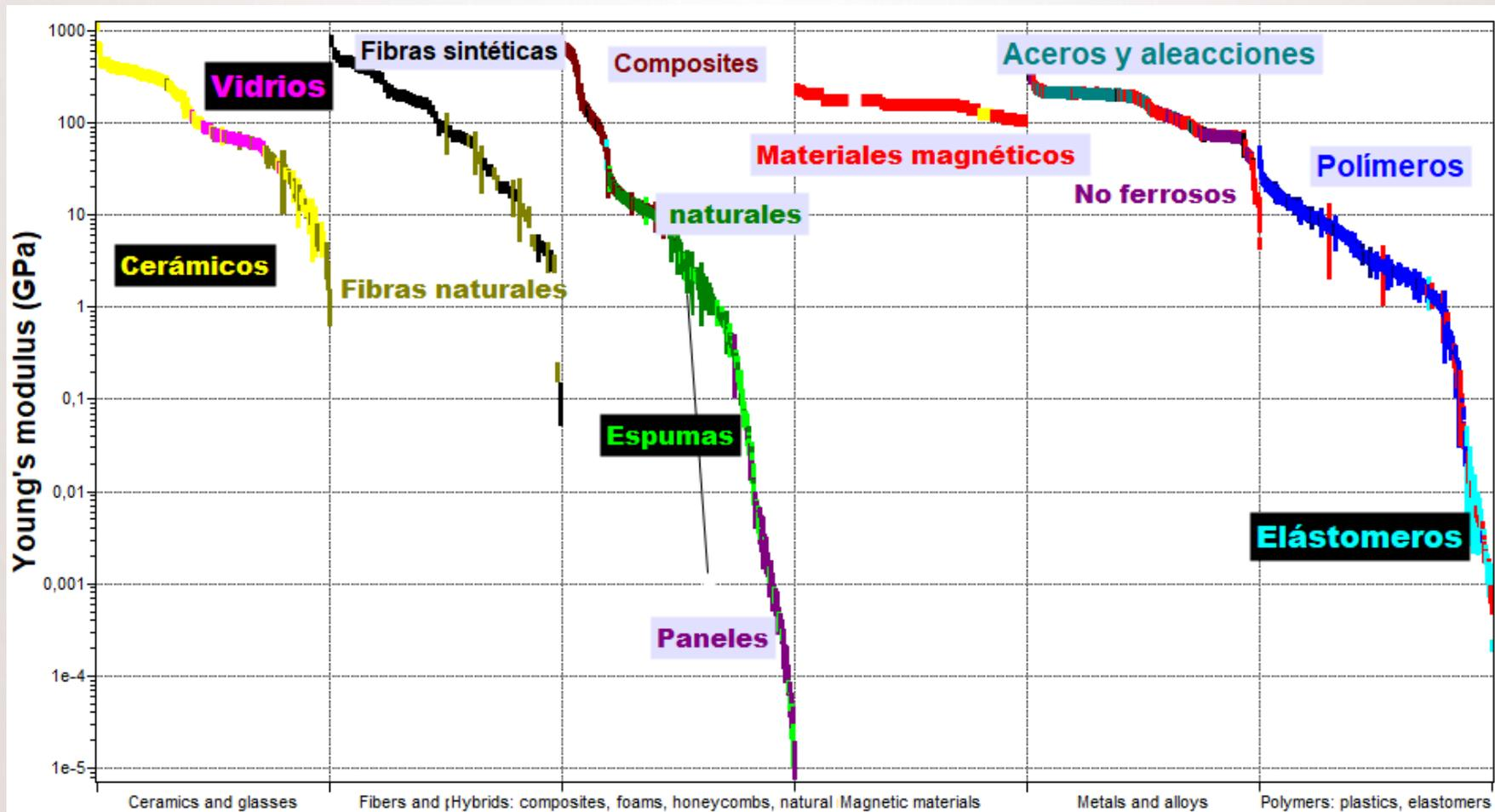

Ensayos de Dureza

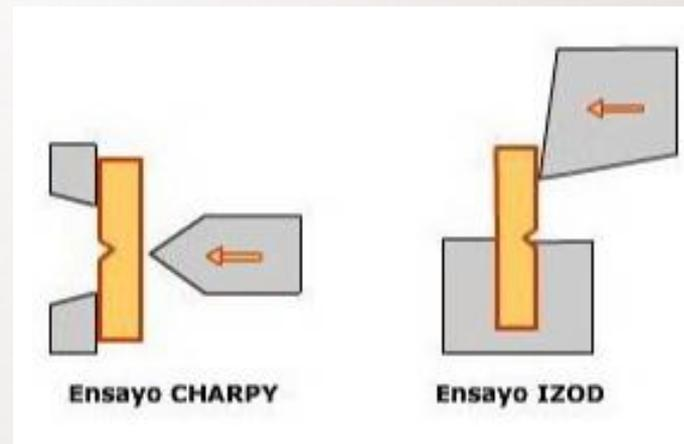
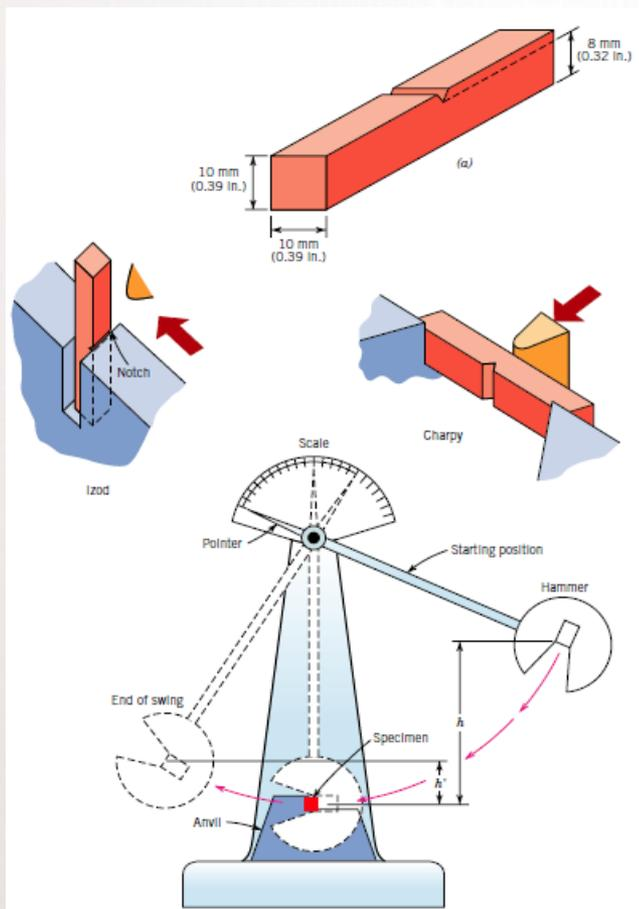



Ensayos de Dureza

Los ensayos de dureza se determinan de acuerdo a :

- La geometría del penetrador
- La carga aplicada
- La forma de medir la huella

Ensayos de dureza:

- **Rockwell (termoplásticos y termoestables): micro-durezas**
- **Brinell (nanoindentación)**
- **Shore (gomas y elastómeros, termoplásticos blandos)**

Dureza Brinell

Características:

- ▶ Penetrador en forma de bola; diámetros 1,2,5 y 10 mm
- ▶ Diferentes cargas: de 1 a 1000 kg.
- ▶ Se evalúa el área de la huella
- ▶ Se necesita una buena preparación superficial
- ▶ Las medidas son comparables siempre que $P/D^2 = \text{cte}$

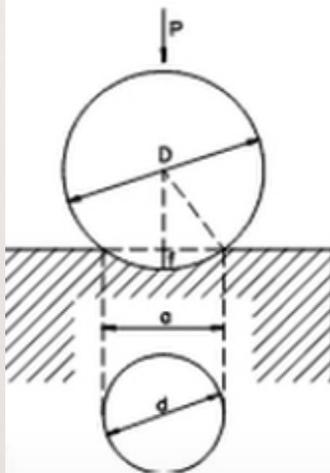

$$HB = \frac{2P}{\pi D \left(D - \sqrt{D^2 - d^2} \right)}$$

p.e. HB 400



Ensayos de Dureza

Material	Brinell, HB
Poliestireno (PS)	20
Nylon (poliamidas)	12
Cloruro de polivinilo (PVC)	10
Polipropileno (PE)	7
Polietileno alta densidad (HDPE)	4
Polietileno baja densidad (LDPE)	2



Ensayos de Dureza

- **Shore (gomas y elastómeros)**

Escalas disponibles shore	Normas
<ul style="list-style-type: none">• Shore A: gomas blandas, ceras y cueros.• Shore B: escala intermedia.• Shore C: gomas y plásticos de dureza media, yeso y escayola.• Shore D: gomas y plásticos duros.• Shore DO: bobinas textiles de alta densidad.• Shore O: bobinas densidad media.• Shore OO: goma-espuma, esponjas y bobinas textiles de baja densidad	<ul style="list-style-type: none">• ISO 868• DIN 53505• ASTM D2240• ISO 7619 -1• ISO 21509• NFT 51109 y BS 903 parte A26• Hardness• Shore



Ensayos de Dureza

Los ensayos de dureza permiten caracterizar al material a través de un método rápido y sencillo

Los ensayos disponibles se diferencian en:

Tipo de penetrador

Carga aplicada

Evaluación de la huella

Polymer Fibers
(Properties)

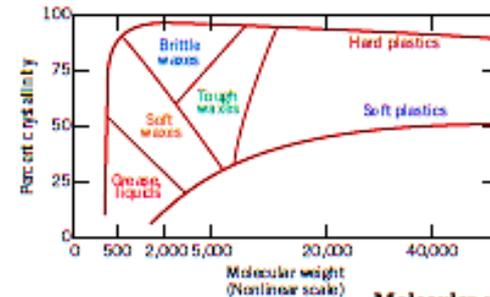
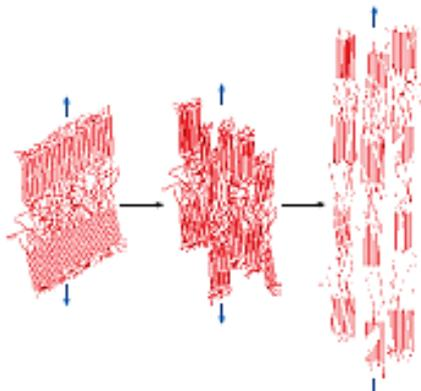
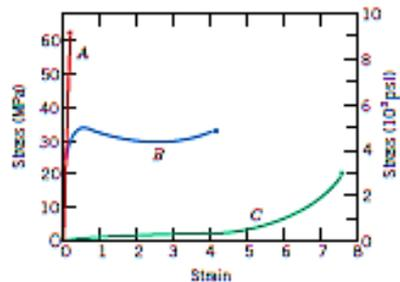

Mechanical behavior (definitions) (Chapter 6)

$$\sigma = \frac{F}{A_0}$$

$$\epsilon = \frac{l_t - l_0}{l_0} = \frac{\Delta l}{l_0}$$

Stress-strain behavior (Chapter 15)

Deformation mechanism (semicrystalline polymers) (Chapter 15)

Macroscopic deformation (necking phenomenon) (Chapter 15)

Factors that influence the mechanical properties (Chapter 15)

- Molecular weight
- Degree of crystallinity
- Predeformation by drawing
- Heat-treating

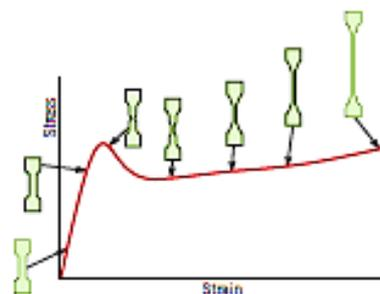



Propiedades Físicas

Ensayos térmicos

Ensayos térmicos: Temp. de transición vítrea (T_g)

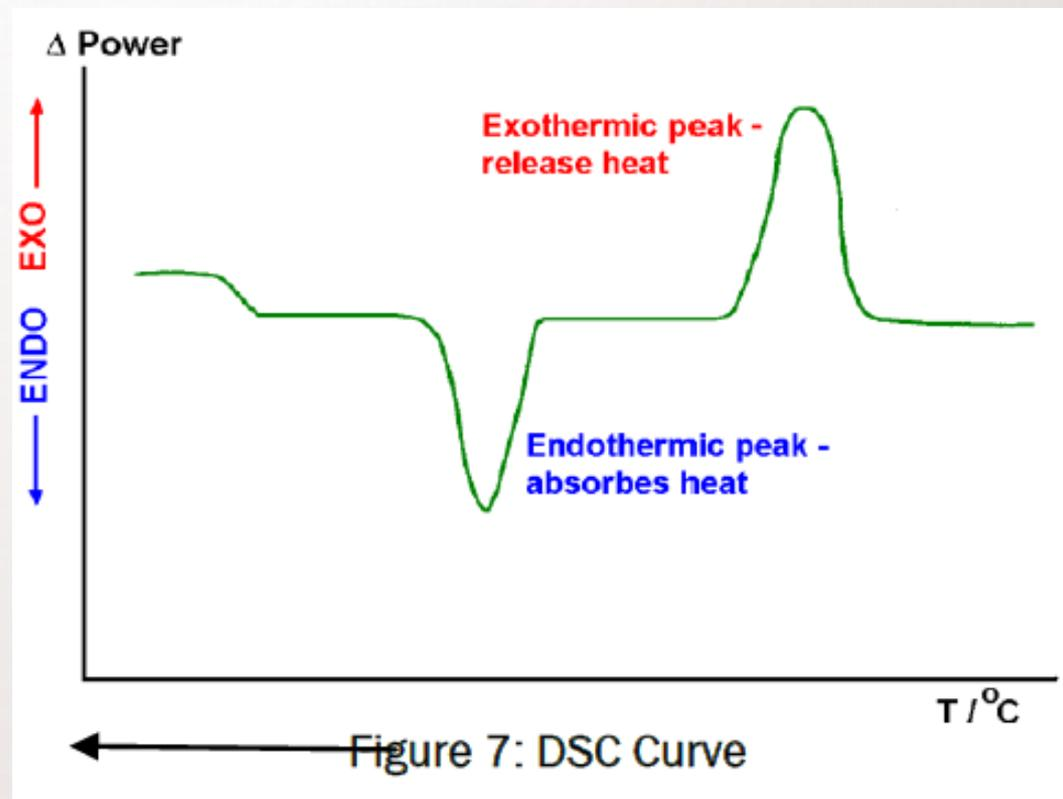

Ensayos térmicos: Temp. de transición vítrea (T_g)

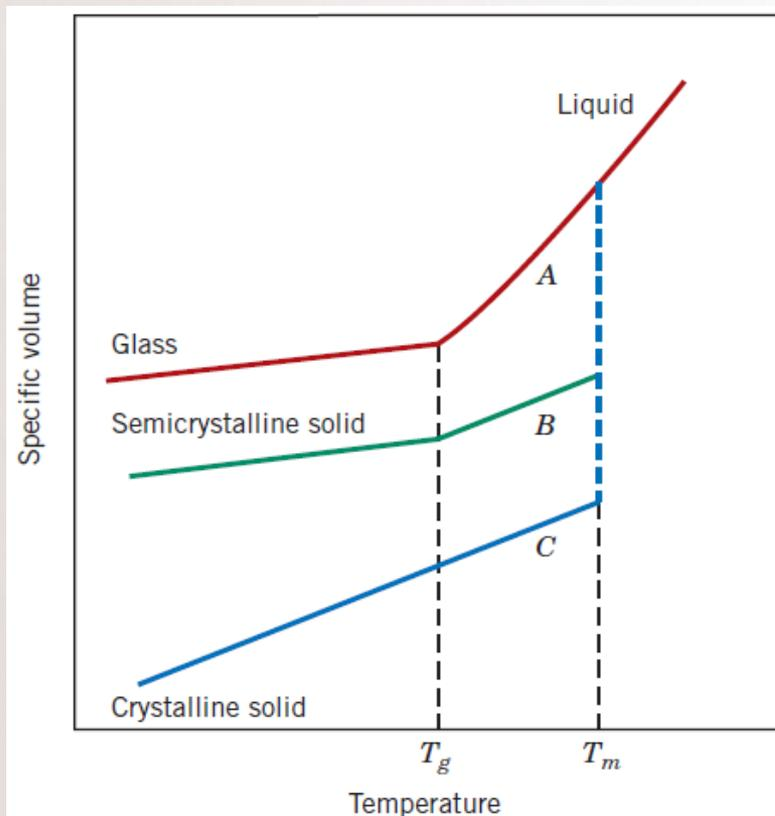
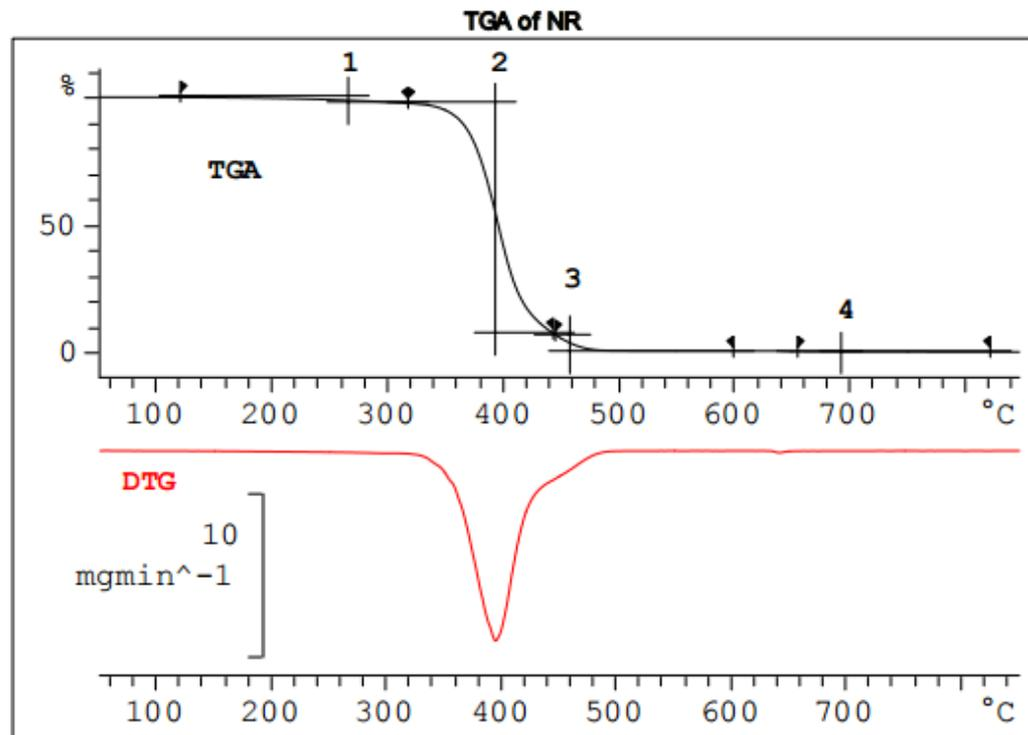

Figure 15.18 Specific volume versus
Table 15.2 Melting and Glass Transition Temperatures for Some of the More Common Polymeric Materials

<i>Material</i>	<i>Glass Transition Temperature</i> [°C (°F)]	<i>Melting Temperature</i> [°C (°F)]
Polyethylene (low density)	-110 (-165)	115 (240)
Polytetrafluoroethylene	-97 (-140)	327 (620)
Polyethylene (high density)	-90 (-130)	137 (279)
Polypropylene	-18 (0)	175 (347)
Nylon 6,6	57 (135)	265 (510)
Poly(ethylene terephthalate) (PET)	69 (155)	265 (510)
Poly(vinyl chloride)	87 (190)	212 (415)
Polystyrene	100 (212)	240 (465)
Polycarbonate	150 (300)	265 (510)

Ensayos térmicos: Análisis termogravimétrico (TGA)





Plásticos con Prop. Termicas y mecánicas

- Flúor polímeros
- Poliimida
- Polietirimida
- Polietersulfona
- Polietercetona
- Poliamidaimida



Plásticos resistentes a altas temperaturas

Al grupo de los plásticos resistentes a altas temperaturas con cadenas principales rígidas pertenecen la Poliimida, Poliamidaimida, Polieteterimida, Polietersulfona, Polietercetona y otros (Tabla 1). (22,23).

Nr.	Nombre	Estruct. química	T _g (°C)	T _m (°C)	E (GPa)	σ _B (MPa)	ε _B (%)
1	PES		225	—	2.6	84	60
2	PPS		200	300	4.2	75	3
3	PEI		217	—	3.3	105	60
4	PIS		275	—	5.0	63	13
5	PEEK		134	335	3.8	100	100
6	LCP		190	280	9.2	196	4

Polietersulfona
POLIFENILSULFONA
POLIETERIMIDA
Poliimido
Polietetercetona
Pol. de Cristal Líquido

Tabla 1: Nuevos plásticos resistentes a altas temperaturas



Elastómeros termoplásticos

Copolimeros en bloque de Estireno

Estireno-butadieno-estireno

Estireno-butadieno-estireno

Estireno-etileno-butileno-estireno

Copolimeros radiales

Estireno-butadieno-estireno

Estireno-butadieno-divinilbenceno



Plásticos con pror. mecánicas especiales

- FIBRAS DE ARAMIDA
- KEVLAR
- POLIESTER
- GRAFITO
- FIBRAS DE C
- FIBRAS DE Si
- POLIAMIDA 6

Fibras de alto módulo E (GPa)

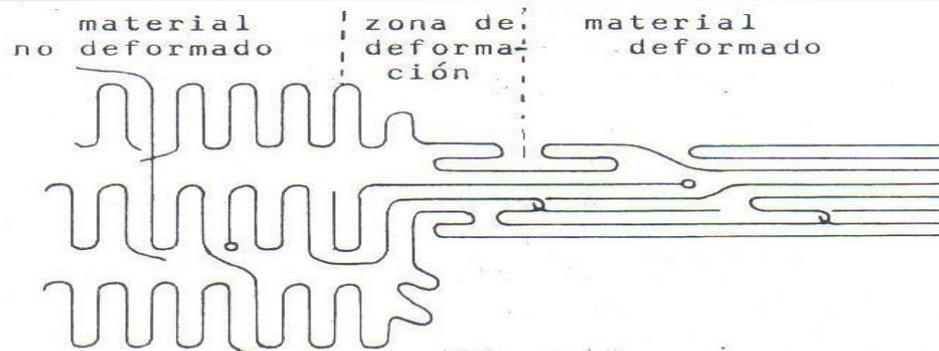

Fig. 2: Representación esquemática del mecanismo molecular durante el estiramiento de plásticos parcialmente cristalinos.

La Fig. 3 muestra el esquema de instalación de un equipo de hilatura a partir de un gel según Smith y Lemstra (DSM)

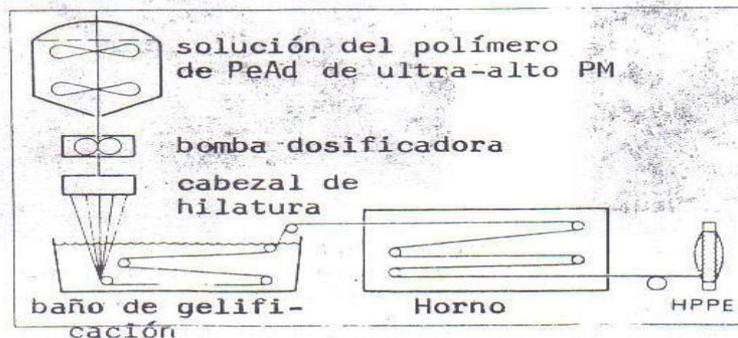

Fig. 3:
Proceso de hilatura a partir de geles de PeAd



Fibras de alto módulo E (GPa)

Tipo de fibra	Módulo a la tracción E (GPa)	
	teórico	valor experimental más alto
Celulosa	120	18
Nylon 66	160	5
Polietileno	300	280
Politereftalato de etileno	200	13
Polipropileno	50	20
Polibuteno 1	40	16
Fibra totalmente aromática (Kevlar)	120	120
Poliacetileno	60	45
Fibra de vidrio	70	70
Fibra de carbono (grafito)	900	390



Propiedades Físicas

Ópticas y eléctricas



Propiedades ópticas y eléctricas

- Brillo especular
- Color
- Índice de refracción
- Resistencia al arco eléctrico
- Resistencia dieléctrica



Nuevos Materiales Poliméricos

Películas piezoeléctricas: polifluoruro de vinilideno (PVDF).

Plásticos conductores de la electricidad

Propiedades ópticas.

Tecnología de membranas.

Termoplásticos degradables biológicamente.



Propiedades Químicas

Temperatura de ignición e inflamabilidad



Prop. Químicas: Temperatura de ignición e inflamabilidad

Calor de combustión de diversos polímeros naturales y sintéticos

PLASTICO	dH (kJ/kg)
HDPE	46.500
PP	46.000
Poli isobutileno	47.000
PS	42.000
ABS	36.000
PVC	20.000
PMMA	26.000
PA 6/66	32.000
Poliéster (termoestable)	18.000
Caucho natural	45.000
Algodón	17.000
Celulosa	17.500



Resistencia química

- **Envejecimiento a la intemperie**
- **Resistencia al ultravioleta**
- **Permeabilidad**
- **Absorción de agua**
- **Resistencia bioquímica**



ORGANIZACIONES DE HOMOLOGACIÓN

A: ASTM (American Society for Testing and Materials)

B: ISO (International Organization for Standardization)

C: UNIDADES DEL SI



TP 2

Realizar una gráfica o carta de Ashby, según sea el caso,

- 1. Teniendo en cuenta la clasificación vista en clase para los materiales poliméricos.**
- 2. Todos los materiales Polímeros vs 2.1) rigidez mecánica (E: módulo de Young), 2.2) ignición e inflamabilidad, 2.3) Costos, 2.4) resistencia a UV, 2.5) ambientes salinos, 2.6) temperatura de servicio superior a 50°C, 2.7) propiedades ópticas.**
- 3. Gomas y elastómeros naturales y sintéticos vs 3.1 rigidez mecánica (E: módulo de Young), 3.2) la resistencia térmica, 3.3) degradabilidad, 3.4) costos y 3.5) disponibilidad.**
- 4. Polímeros naturales vs sintéticos usados en la industria de: 4.1) empaques, 4.2) textil, 4.3) Biomédica.**

Analizar costos, disponibilidad y recomendaciones.